

# Operating instructions MBA800

Digital Paddle Level Indicator  
with ATEX Certification



- Installation
- Operation
- Maintenance



## Document information

### Document identification

Title: Level indicator series MBA800  
 Order number: 8011610  
 Version: 4.0  
 Dated: 2019-07

### Described product

Product name: MBA800  
 Variations: MBA810, MBA820

### Manufacturer

MBA Instruments GmbH  
 Friedrich-List-Straße 3-7, GERMANY, 25451 Quickborn

### Warranty information

The given product characteristics and technical data do not constitute a declaration of warranty.

© MBA Instruments GmbH. All rights reserved.

## Meaning of the warning symbols



General danger



Danger from electrical voltage



Danger in potentially explosive areas



Danger due to high temperature or hot surfaces

## Warning levels

### WARNING

Risk or hazardous situation which could result in severe personal injury or death.

### CAUTION

Hazard or unsafe practice which could result in personal injury or property damage.

## Explanation of the information symbols



Important technical information for this product.



Important information on electrical or electronic functions



Supplemental information



Tip

## Content

<b>1</b>	<b>Product overview</b> .....	<b>3</b>
<b>2</b>	<b>Product description</b> .....	<b>4</b>
2.1	Device components .....	4
2.2	Principle of operation .....	4
2.3	Product variations .....	4
2.4	Optional equipment .....	4
2.5	Appropriate use .....	4
2.6	Responsibility of the user .....	4
2.7	Safety information for use in EX locations .....	5
<b>3</b>	<b>Installation</b> .....	<b>6</b>
3.1	Installation location, protective roof .....	6
3.2	Assembly .....	6
3.3	Installation .....	7
3.3.1	Operating conditions .....	7
3.3.2	Installation position .....	7
3.3.3	Fastening .....	7
3.3.4	Temperatures of the distance tube .....	8
3.4	Electrical connection .....	8
3.4.1	Safety notes for the installation .....	8
3.4.2	Power cord .....	8
3.4.3	Protection against explosion .....	8
3.5	Wiring diagram .....	9
3.5.1	With M12 plug connector .....	9
3.5.2	Connect supply voltage .....	9
3.5.3	Connect output signals .....	9
3.5.4	Connect external signal voltage .....	9
3.5.5	Connect external LEDS (if required) .....	9
3.6	Setting/Adjustment .....	10
3.6.1	Select switch logic .....	10
3.6.2	Select function mode .....	10
3.6.3	Adjust sensitivity .....	10
3.6.4	Select signal voltage .....	10
3.7	Closing the housing .....	10
3.7.1	Sealing the cable glands .....	10
3.7.2	Close housing .....	10
<b>4</b>	<b>Start-up</b> .....	<b>11</b>
4.1	Switch-on .....	11
4.2	Function test at first start-up .....	11
4.2.1	Check operability .....	11
4.2.2	Check for triggering by the bulk material .....	11
<b>5</b>	<b>Maintenance</b> .....	<b>11</b>
5.1	Recommended maintenance work .....	11
5.2	Preventive functional check .....	11
5.3	Internal malfunctions .....	11
5.3.1	Electronic self-monitoring .....	11
5.4	Safety information for opening .....	11
5.5	Removing the unit head (note) .....	11
<b>6</b>	<b>Technical data</b> .....	<b>12</b>
6.1	Identification .....	12
6.2	Specifications on the rating plate .....	12
6.3	Electrical data .....	12
6.4	Ambient conditions .....	12
6.5	Product materials .....	12
6.6	Dimensions .....	13

# 1 Product overview

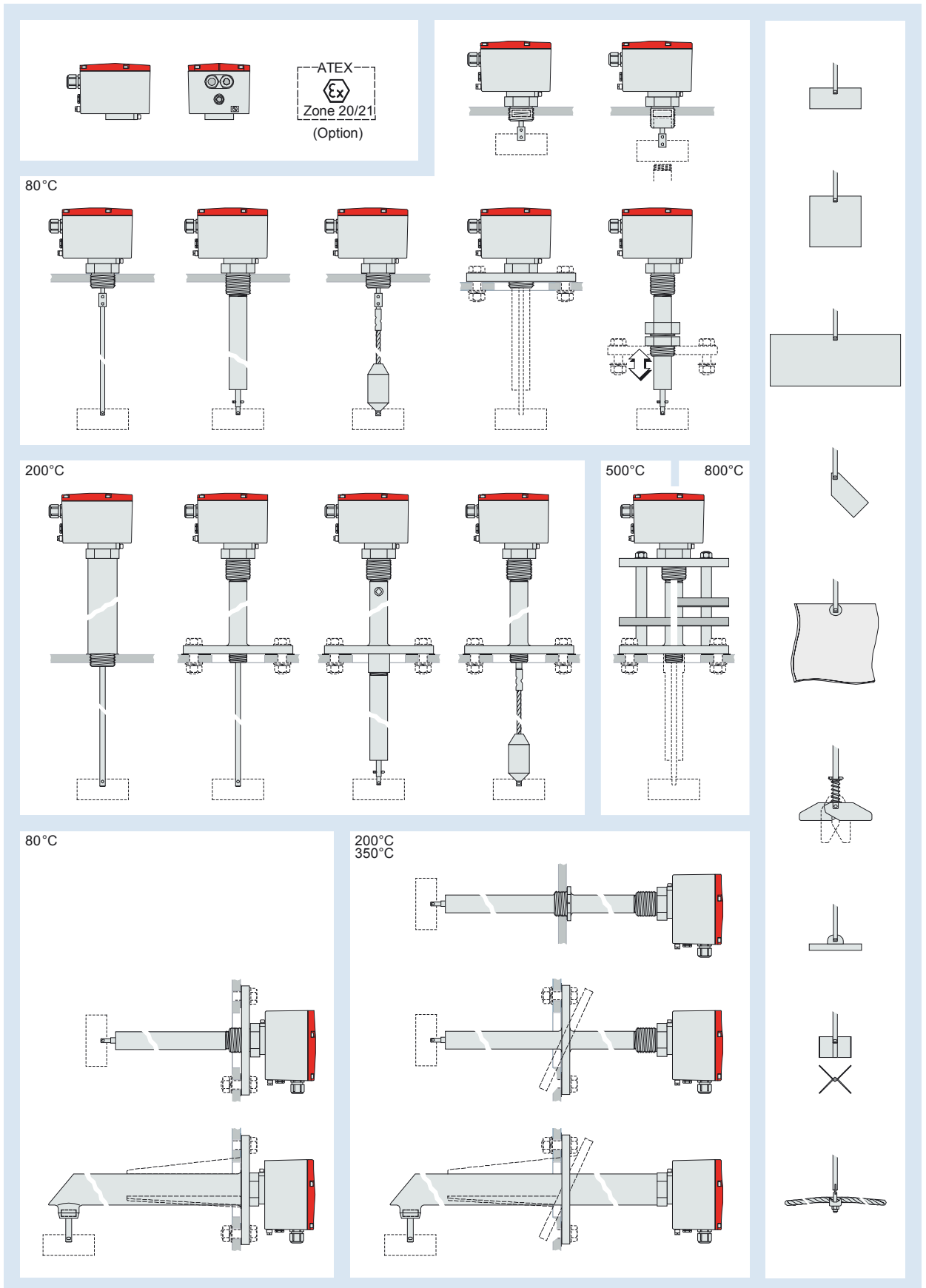

## 2 Product description

### 2.1 Device components

- 1 **Unit head:** Contains the drive system and electronic components. Two different types available.
- 2 **Process connection:** thread or flange. Attached to the outer wall of the bulk material container. Contains the shaft bearing and holds the unit head on the outside and the protective tube (if provided) on the inside. Many versions available for adaptation to the actual bulk materials container
- 3 **Shaft:** Connects the paddle to the unit head. Variations: various lengths available (long lengths divided into two sections); a steel cable as a flexible shaft.
- 4 **Paddle:** Stops the shaft rotation when the bulk material surrounds the paddle. Variations: solid/flexible/foldable; size; material.
- 5 **Protective tube (option):** Covers the shaft inside the bulk material container. Variations: protective tube for vertical installation, open (long lengths delivered in two sections); protective tube for horizontal mounting with additional shaft bearing at the end; angled extension arm for horizontal mounting with angled, vertical shaft.

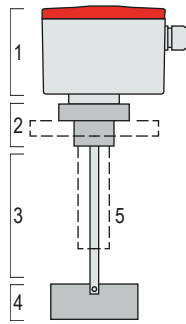

### 2.2 Principle of operation

A stepper motor in the unit head makes the shaft and paddle rotate slowly. When the bulk material surrounds the paddle, the rotation is blocked. This condition is detected electronically. In the normal function mode, the stepper motor is then stopped immediately. In the function mode with a reversal of direction, the direction of rotation is reversed instead. Only when the paddle is blocked in this direction of rotation as well is the stepper motor stopped.

The blocked condition is signalled by a switch contact. As soon as the bulk material releases the paddle again, the stepper motor starts again automatically. The status signal is deactivated and the paddle continues to rotate.



- The torque and response behaviour can be adapted to the application case (→ page 11, §3.5).
- The function mode with a reversal of direction is very well suited for moving bulk materials (e.g. for reliable detection of backing-up).

### 2.3 Product variations

- MBA810: Version for grid voltage (115...230 V AC).
- MBA820: Version for 24 V DC.

### 2.4 Optional equipment

- **Display lamp:** Indicates the current status.
- **Compensating membrane:** Moisture and pressure compensating membrane on the unit head; safety requirement for operation on containers with high pressure inside (option "10 bar"). Acts as a bursting disc if the pressure in the unit head suddenly increases in the event of a malfunction (> 2 bar).
- **Height adjustment:** A clamp-ring fitting which holds the protective tube of the extension arm and can secure it at different insertion depths.

### 2.5 Appropriate use

#### Application area

Level indicators of the MBA800 series are robust electromechanical sensors to detect the presence of bulk material at the place of installation. They are designed to monitor the filling of a bulk material container. Possible applications depend on the configuration of the individual unit.

Bin level indicators of the MBA800 series can be used with industrial bulk materials from organic and mineral substances. The unit must not be affected by chemically aggressive gases or fluids.



#### CAUTION: Explosion hazard

An MBA800 level indicator may only be used in potentially explosive locations if the individual specification of the unit complies with this use.

- ▶ Check rating plate and accompanying papers.
- ▶ The requirements of the EC type examination certificate must be observed.



If there is any doubt whether or not the unit is suitable for the individual application case, contact the manufacturer.

#### Design options

Variable design features are, for example:

- paddle size, shape and material
- material and construction of the rotating shaft
- sealing between the housing and rotating shaft

The corresponding properties for the unit can expand or restrict the range of possible applications (e.g. suitability for a particular type of bulk material).

Please observe the individual specifications of the delivered unit.

### 2.6 Responsibility of the user

- ▶ Use the device only as described in these Operating Instructions. The manufacturer assumes no responsibility and no warranty for any other use.
- ▶ In addition to these Operating Instructions, follow all local laws, technical rules and internal company operating directives applicable at the respective installation location of the unit.
- ▶ No components may be removed from, added to or changed on the unit unless this is described and specified in the official manufacturer's information.
- ▶ *In potentially explosive areas:* Prior to installation and operation, observe the European standard EN 60079-14.



EN 60079-14: Electrical apparatus for use in the presence of combustible dust – Part 14: Selection and installation

Product versions which are certified for use in potentially explosive locations have been tested and approved according to 60079-0 and EN 60079-31.

## 2.7 Safety information for use in EX locations

- A level indicator of type MBA8x0 may only be used in potentially explosive locations if the individual specification of the unit complies with this use.
- Do not open when it is under voltage.
- After switching it off, wait 40 minutes before opening it.
- The temperature at the wire branching point can be up to 80°C. Only harmonised cable may be used.
- A melting fuse with a circuit-breaking capacity of at least 1500 A must be connected ahead.
- Check the unit based on the rating plate and delivery slip in connection with the certification (ATEX).
- An approved unit bears the following marking:  
II 1/2 D Ex ta/tb IIIC T100°C Da/Db
- The EC type examination certificate is an integral part of the Operating Instructions.
- Observe the regulations of the approvals
- Install a potential equalisation connection
- Prevent sparking from striking metal parts.
- Carry out the installation in accordance with the standard EN 60079-14.
- Observe zone separation (see 'Use' section).
- Only perform the electrical installation in a suitable terminal housing.
- For process temperatures above +80 °C, suitable measures must be taken to ensure that the housing temperature at the transition from the shaft housing to the electronics box does not exceed +50 °C.

## Responsibility of the user

- Use the device only as described in these Operating Instructions. The manufacturer assumes no responsibility and no warranty for any other use.
- In addition to these Operating Instructions, follow all local laws, technical rules and internal company operating directives applicable at the installation site of the unit.
- Observe the specifications in connection with the voltage and temperature on the rating plate.

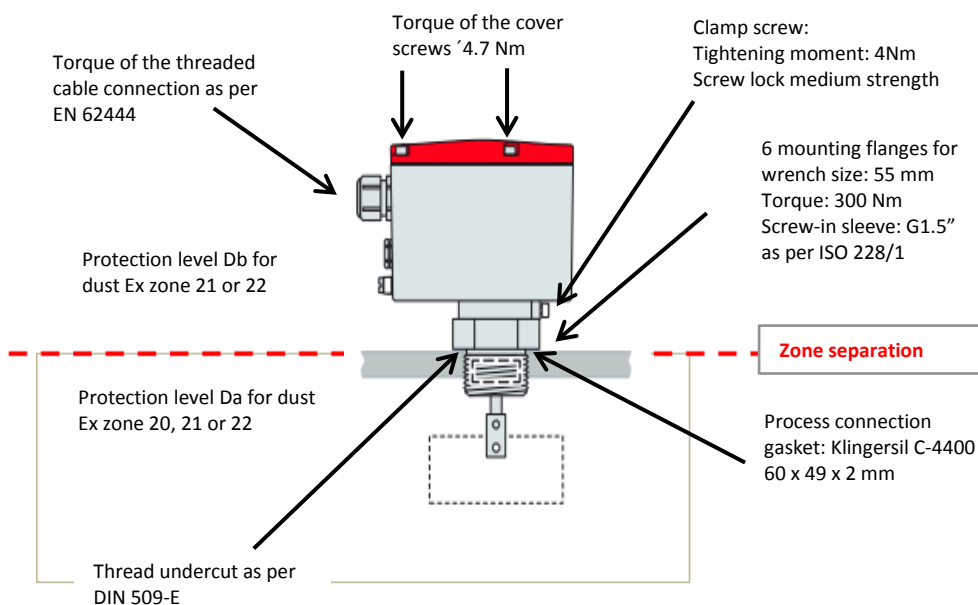

## Use

The MBA8x0 is used as a level detection switch for all types of bulk materials. The unit must only be used for permanent installation in industrial plants (large tools). The unit is designed for zone 21. Furthermore, the shaft end and paddle can be introduced in zone 20 if the process connection is installed in a partition wall and there is adequate seal tightness from the installation. The seal tightness of the process connection in terms of zone separation was not tested during the course of the EC type examination and must be ensured by the user.

## Conformity:

### Explosion protection, general requirements

EN 60079-0 :2012+ A11:2013

### Equipment dust explosion protection by enclosure "t"

EN 60079-31:2014

### EMC:

EN 61000-6-4: Sept. 2011 (industrial area)

EN 61000-6-2: March 2006 (industrial area)

### Vibration:

IEC 60068-2-6, IEC 60068-2-27

### Low voltage:

EN 61010-1: 2011

### 3 Installation



No components may be removed from, added to or changed on the unit unless this is described and specified in the official manufacturer's information. Otherwise the any warranty of the manufacturer becomes invalid, and the approval for use in potentially explosive locations (if provided) is no longer valid.

#### 3.1 Installation location, protective roof

- ▶ If at all possible, place the level indicator in a position where falling bulk material will not directly strike the shaft or paddle.

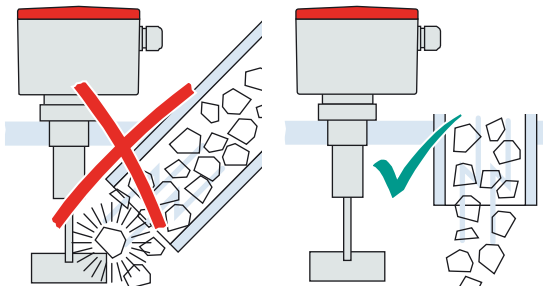

For heavy bulk materials that could damage the shaft or the paddle:

- ▶ If required, install a stable deflector or protective roof in the container which protects the shaft and the paddle against direct impact of falling bulk material.

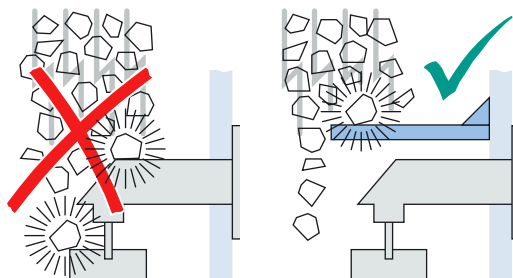

If the bulk material is heavy or can form large clumps:

- ▶ Install a stable protective roof in the container to shield the shaft (and the extension arm) from the weight of the bulk material.
- ▶ Provide sufficient space between the protective roof and paddle to make sure that the bulk material can reach the paddle.

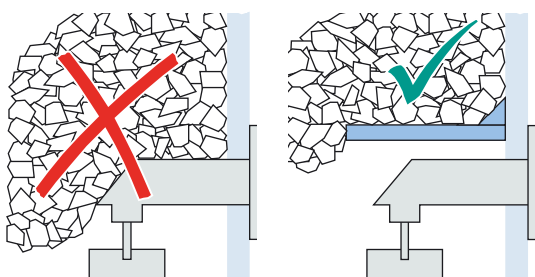

#### 3.2 Assembly

Only necessary if the shaft, paddle, and protective tube were shipped dismantled.

- ▶ **Install the shaft:** Guide the end of the shaft into the shaft sleeve of the unit head. Use the supplied split-pin to connect both parts (push it through and spread it out). – For multi-part shafts, join the parts of the shaft in the same way.
- ▶ **Assembling the protective tube** (for multi-part protective tubes): Take the locking screws out of the connecting coupling sleeve. Screw one of the protective tube parts into the coupling sleeve – up to about the middle of the sleeve. Then screw-in the other part from the other side and firmly attach both parts of the protective tube. – *Recommendation:* Now make two small counter-sunk holes in the coupling sleeve sections, which will fix the position of the locking screws (use a max. 3.2 mm diameter drill guided through the screw holes of the coupling sleeve). – Put in the locking screws and tighten.
- ▶ **Install the protective tube** (for units with a protective tube): Apply a thread-locking agent (such as "Loctite") to the thread of the protective tube and screw it into the threaded sleeve as far as it goes.
- ▶ **Shortening the flexible cable shaft** (if required): Remove the tensioning weight from the end of the cable (undo the locking screw and pull out the cable). At the place where the cable must be cut, wrap some adhesive tape firmly around the cable to protect against wire particles shooting from the cable. Wear protective goggles. Then cut the cable with a suitable wire cutter or a cutting disk "Flex", for example. Remove adhesive tape residue and attach the tensioning weight again.
- ▶ **Install the paddle:** Guide the flat end of the paddle into the slot of the shaft and attach it with the supplied split-pin or roll pin (push it through and spread it out).

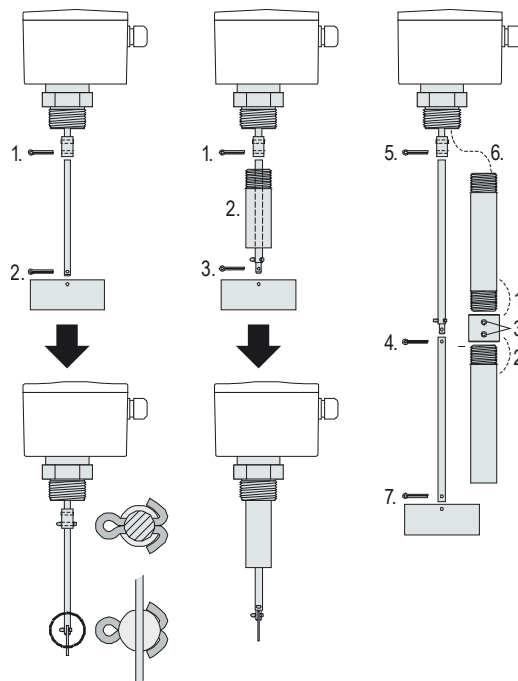

1 ... 7 = Order of assembly



It may be necessary (or advantageous) to install the paddle at the very end of the installation procedure.

- ▶ *Recommendation:* Apply a thread-locking agent (such as "Loctite") to all the locking screws.

### 3.3 Installation

#### 3.3.1 Operating conditions

- ▶ Observe the temperature specifications on the rating plate (example → page 10, § 6.2, explanations → page 4, § 2.5).
- ▶ Keep the following pressure limits:

Standard version:	-50 ... +300 kPa (-0.5 ... +3.0 bar)
Version "D10" (with burst membrane on the unit head):	max. 1,0 MPa (10 bar)
In potentially explosive areas:	80 ... 110 kPa (0.8 ... +1.1 bar)

#### 3.3.2 Installation position

- ▶ *Units without additional shaft bearing in the extension arm:* Use only with a vertically suspended shaft ( $\pm 5^\circ$ ).

Exception: If the shaft is rigid and not longer than 200 mm and the bulk material is light, an angle of inclination of max.  $90^\circ$  is permissible (allows side mounting with horizontal shaft).

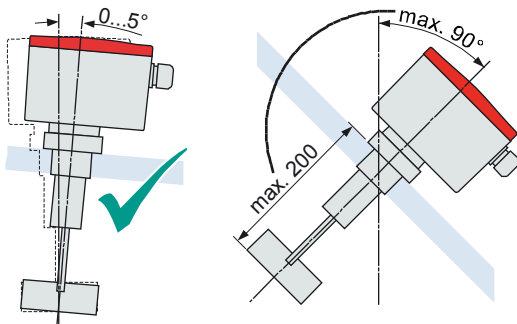

- ▶ *For lateral installation (horizontal shaft):* Install the unit in such a way that the cable connections are on the underside of the housing.

The unit head can be turned (2) after the clamping screw (1) on the underside has been released.

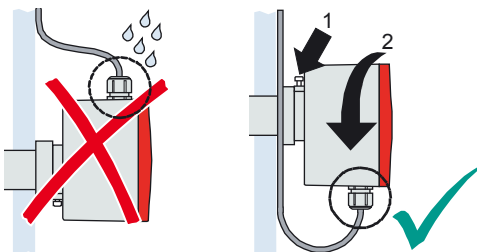

In operating condition, the clamping screw must be fixed.

- ▶ After the adjustment the device head must be tightened at the medium strength through the clamp screw by using a screw lock. (clamp screw: 4 Nm).

### Fastening

#### Standard versions

- ▶ Attach the MBA process connection to the container. (dimensions → page 11, § 6.6).
- ▶ *For protection class IP 65 (EN 60529):* Provide a suitable water/dust seal between unit and container.

#### Version with height adjustment (option)

The height adjustment device is a clamp-ring fitting that can secure the protective tube at variable insertion depths.

- Mount the clamp-ring fitting or alternatively the flange with the clamp-ring fitting on the container.
- Put the coupling nut and the clamping ring of the clamp-ring fitting over the protective tube.
- Guide the protective tube through the compression fitting (caution: do not damage the sealing rings inside the fitting) and bring it into the desired position.
- Guide the clamping ring into the fitting. Screw-up and tighten the clamping nut.
- Attach the paddle.

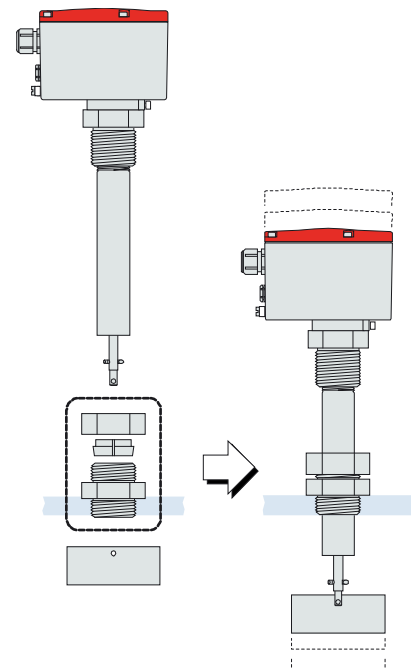

#### Temperature protection by height adjustment

The height adjustment device can also be used to keep the unit head away from high temperatures in the container.

Observe the following during the installation.

- ▶ Adjust the height to a level where the distance between unit head and container is at least 200 mm.
- ▶ *If the container is equipped with thermal insulation:* Remove the thermal insulation around the protective tube (instructions → page 7, § 3.3.4).

Under these conditions, the unit can be used with container temperatures up to 200 °C.

### 3.3.3 Temperatures of the distance tube

Unit versions for container temperatures above 80 °C are equipped with a distance tube between unit head and connection thread/flange. The purpose of the distance tube is to keep high temperatures away from the unit head (max. 60 °C).

- ▶ If the container is equipped with thermal insulation: Keep the entire length of the distance tube free of thermal insulation, in order to allow cooling by the ambient air. Do not cover the distance tube with the insulation of the container.
- Otherwise the distance tube will not provide the required cooling effect and the unit head could overheat. The consequence is a loss of the function, damage.

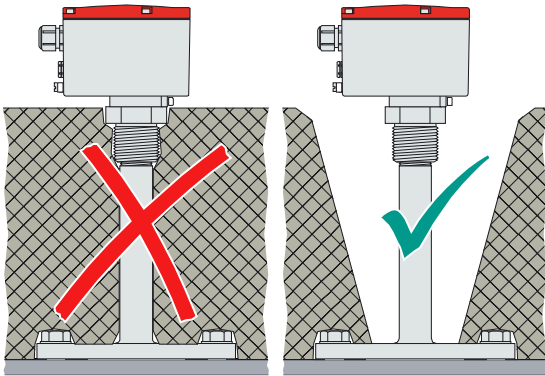

**WARNING: Risk of injury**  
The distance tube is possibly hot enough to burn skin immediately when touched.  
▶ *If the container is hot:* Protect the distance tube against accidental touching.



**WARNING: Risk of explosion from dust deposits**  
The surface temperature of the distance tube can be significantly higher than the unit head temperature.  
▶ Check if the dust-explosion limit value can be exceeded when the surface of the distance tube is covered with dust due to the high temperature of the distance tube.  
▶ If this hazard exists: Make sure that the distance tube cannot be contaminated with dust, or that the dust is periodically removed as a preventive measure.

## 3.4 Electrical connection

### 3.4.1 Safety notes for the installation



**CAUTION: Exposed contacts inside the unit**  
The electrical contacts inside the unit are not protected against accidental contact.  
▶ Before opening the unit head, shut off the mains power supply and all connected signal voltage.



▶ Have the unit installed and put into operation by specialists who can carry out this work properly and are familiar with possible dangers.



The unit has neither a mains switch nor mains fuse.  
▶ Install an isolating switch in the supply voltage line which can switch the mains power supply off.  
▶ Install an external fuse for the supply voltage (power consumption → page 12, §6.3).

### 3.4.2 Power cord

- ▶ Use a power cord with the following conductor cross sections:
  - Solid conductor: max. 2.5 mm<sup>2</sup>
  - Stranded conductor: max. 1.5 mm<sup>2</sup>
- ▶ Use cables that are specified for an ambient temperature of at least 80 °C
- ▶ Protect all cables against heat. Avoid contact with hot surfaces (for example, the container wall). Consider thermal radiation and heat accumulation.

### 3.4.3 Protection against explosion



**WARNING: Explosion hazard**  
If the unit is used in a potentially explosive location, the following criteria must be observed:

- ▶ **Approval:**
  - Check if the unit is suitable for use in potentially explosive locations based on the rating plate and delivered documents.
  - Observe the “special conditions” which are specified in the approval.
- ▶ **Potential equalisation:** In addition to the protective earth connection (PE), install a potential equalisation connection. Use the terminal on the outside of the unit head for that purpose.

Potential equalisation screw with eyelet, d=4



- ▶ **Housing temperature:** For process temperatures above 50 °C, suitable measures must be taken to ensure that the housing temperature at the transition from the shaft housing to the electronics box does not exceed 50 °C. The unit may also be used at higher process temperatures up to +200 °C if suitable measures are taken to ensure that the temperature of the shaft housing does not exceed the temperature given above. If the housing temperature of 50 °C cannot be complied with due to higher process temperatures, then suitable cooling measures (e.g. a cooling zone) must be taken.
- ▶ **Cable:** Use only cables that are suitable for the cable glands. For standard versions of the unit, the outer diameter of the cables must be 7 ... 12 mm.
- ▶ **Permanent installation:** Firmly install all connected cables, which means fasten the cables along the entire length so that the cables are protected against electrostatic charging.
- ▶ **Sparks:** Prevent the generation of sparks in the container. Sparks can be generated when the shaft or the paddle collides with metal parts. For units equipped with a flexible cable shaft, sparks could be produced when the shaft cable swings and the paddle collides with the container wall.
- ▶ **Installation standard:** Carry out the installation in accordance with the standard EN 60079-14.



### 3.5 Wiring diagram

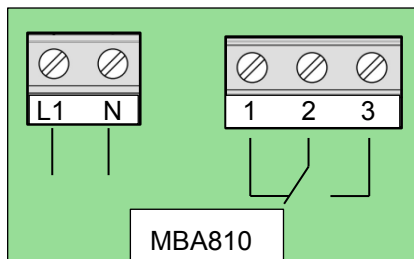
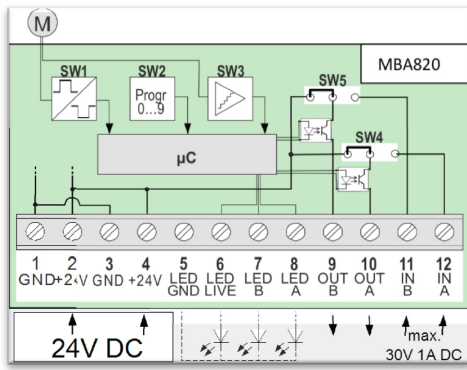

- L1 115 .. 230V AC operating voltage
- N 0
- 1 Switch contact NC (normally closed)
- 2 Main contact
- 3 Switch contact NO (normally open)

#### 3.5.1 With M12 plug connector

A 5-pin M12 coupling with A-coding is required for the electrical connection



- The cable must be installed firmly.
- Only plug in and remove the connector when it is voltage-free.
- After connecting the plug connector on the device, the locking clip must be installed.

#### Pin assignment of the coupling

PIN	Description		Terminal
1	Operating voltage	24 V DC ± 10%	2
2	Output signal	0 / 24 V	10
3	GND	0 V	1
4	Operating status	0 / 24 V DC	11

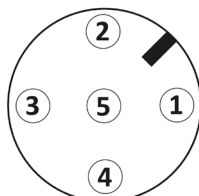

#### Locking clip

The locking clip prevents the plug connector from being removed unintentionally. To install it, place both ends around the connector and press them together until both halves snap into place.

#### 3.5.2 Connect supply voltage

##### MBA810

Connect the supply voltage 115V ..230V 50/60Hz to terminals "L1" and "N". Or 24V DC on „+24V" and „GND"

##### MBA820

Connect the supply voltage to terminals "+24V" and "GND".



- Specification of the supply voltage – page 12 §6.3
- Overtemperature protection – S.12 §5.3.2



There are two connection terminals so that the supply voltage can be forwarded from here ("looped").

#### 3.5.3 Connect output signals

##### Function of the output signals

Output	Function	Output situation
OutA	Level status <sup>1</sup>	<i>If activated:</i> Supply voltage or InA <sup>2</sup>
OutB	Operation	Supply voltage or InB <sup>2</sup>

<sup>1</sup> Optionally "full" or "empty" (→ page 11 §3.5.1).

<sup>2</sup> Optionally (→ §3.5.4).

##### Reference potential of the output signals

The reference potential (–) of "OutA"/"OutB" depends on which signal voltage is selected (→ §3.5.4):

- *If "internal" is selected:* Reference potential = GND.
- *If "external" is selected:* The outputs are potential-free; the signal voltage comes from "InA" or alternatively "InB" without a galvanic connection to GND.



- Operating mode "Function test" → page 11 §3.5.2
- Electronic self-monitoring → page 12 §5.3.1

#### 3.5.4 Connect external signal voltage

Only needed if external signal voltages are to be used for OutA/OutB.

Input	Function
InA	Signal voltage (+) for OutA
InB	Signal voltage (+) for OutB

The reference potential (–) for the signal connections is GND.

► *If InA/InB are to be used:* Test/select the right setting (→ page 11 §3.5.4).

#### 3.5.5 Connect external LEDs (if required)

There are three outputs for status LEDs. The LEDs on the electronics card work identically.

##### LED outputs

- Output signal: +3 V DC
- Load capability per LED output: max. 25 mA
- Reference potential (–): GND.

##### LED functions

LED	State	Meaning
Live/Alive (blue)	off	No supply voltage
	on	Paddle rotating (motor on)
	flashes slowly	Paddle is blocked (motor off)
	flashes quickly	Blockage is being checked (motor on)
OutA (green)	off	Switch SW1 to I Paddle rotating
OutA (green)	on	Switch SW1 to II Paddle rotating
OutB (red)	on	Operation

### 3.6 Setting/Adjustment

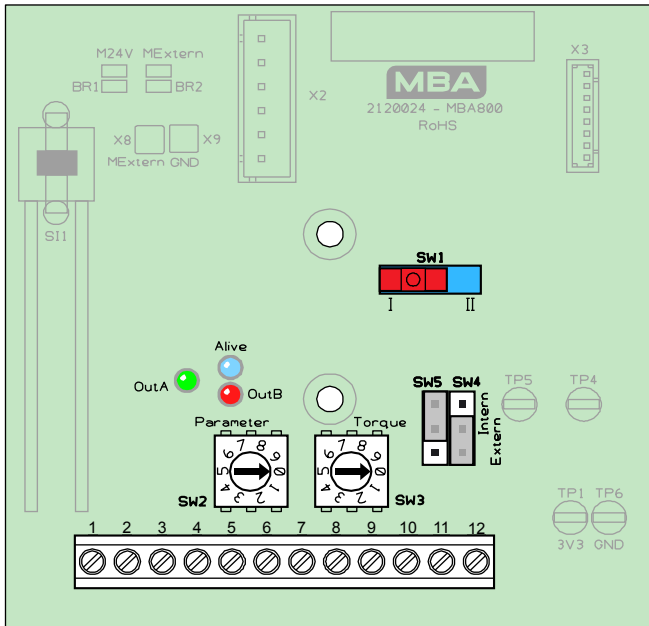

#### 3.6.1 Select switch logic

<b>SW1</b>	Level status (OutA) "activated" means:
<b>I</b>	Signal comes when paddle blocked (full)
<b>II</b>	Signal comes when paddle rotates (empty)

#### 3.6.2 Select function mode

At the shaft type "halfpipe (code: R, P, V, W) it is only allowed to use SW2 at position 0.

<b>SW2</b>	Recommended application
<b>0</b>	Silo full sensor [with reversal of direction] <sup>1 2</sup>
<b>1</b>	Silo full sensor
<b>2</b>	Buffer storage / buffer silo: full
<b>3</b>	Back-up sensor [with reversal of direction] <sup>1</sup>
<b>4</b>	Loading apparatus
<b>5</b>	Silo empty sensor
<b>6</b>	Buffer storage / buffer silo: empty
<b>7</b>	Bulk material high flowing ability/low cohesion
<b>8</b>	Special application <sup>3</sup>
<b>9</b>	Functional test <sup>4</sup>



The operating behaviour is also affected by  
 – the properties of the bulk material  
 – torsion effects (e.g. cable shaft, rubber paddle).

#### 3.6.3 Adjust sensitivity

SW3	Switching torque	
	Relative	Absolute
<b>0</b>	< 5 %	Very low switching torque, only for special application
<b>1</b>	< 10 %	
<b>2</b>	15 %	35 mNm
<b>3</b>	20 %	46 mNm
<b>4</b>	25 %	58 mNm
<b>5</b>	30 %	69 mNm
<b>6</b>	40 %	92 mNm
<b>7</b>	50 %	115 mNm
<b>8</b>	60 %	138 mNm
<b>9</b>	80 %	184 mNm



- ▶ For light, smooth bulk material, select a low switching torque. For heavy, coarse bulk material, select a high switching torque.
- ▶ If there is no empirical value: Determine the right setting during the initial start-up.

#### 3.6.4 Select signal voltage

<b>SW4</b>	Output of OutA (if activated)
<b>Internal</b>	Supply voltage
<b>External</b>	Signal voltage of InA
<b>SW5</b>	Output of OutB (if activated)
<b>Internal</b>	Supply voltage
<b>External</b>	Signal voltage of InB



If "external" is selected, then outputs "OutA"/"OutB" are potential-free (→ page 10 §3.4.6).



For the **MBA810**, SW4 must be set to "internal" so that the function of the relay is given.

### 3.7 Closing the housing

#### 3.7.1 Sealing the cable glands

- ▶ After installation of the cables, seal the cable glands so that they are dust-tight and water-tight.
- ▶ Unused cable glands must only be sealed with original sealing plugs in accordance with the manufacturer's specifications.

#### 3.7.2 Close housing

- ▶ Before closing cover of the unit, check whether there are any foreign bodies inside the unit head (such as cable residue).
- ▶ Visually check the sealing of the cover of the unit. Clean or replace if necessary.
- ▶ Put on the cover of the unit and tighten the screws using 4.7 Nm.
- ▶ The cap nuts must be tightened with the following torque:  
 Plastic threaded cable gland: 4.5 Nm +/- 10%  
 Metal threaded cable gland: 8 Nm +/- 10%

1 Explanation → page 5, § 2  
 2 Factory setting  
 3 Configured according to customer request  
 4 If the paddle is rotating: Status of "OutA" changes every second. If the paddle is blocked: "OutA" is activated permanently.

## 4 Start-up

### 4.1 Switch-on



**WARNING: Health risk / explosion hazard**

During operation, the unit head and the cable gland(s) must be correctly closed and sealed. Otherwise the specified type of protection and the specified explosion protection (option) is not guaranteed.

- After switching on the supply voltage, the paddle turns at high power for around 1 minute.
- After that, the MBA800 is operational.

### 4.2 Function test at first start-up

#### 4.2.1 Check operability

After the first start-up, check the indicating function:

- ▶ Allow the paddle to rotate freely → check status of "OutA"
- ▶ Stop the paddle by hand → check status of "OutA"



The status of "OutA" depends on whether "full sensor" or "empty sensor" is set (→ §3.6.1).

#### 4.2.2 Check for triggering by the bulk material

- ▶ Carefully fill or alternatively empty the bulk material container up to the level indicator. Watch the process and check whether the level is shown correctly.
  - ▶ *Recommendation:* Perform this test several times.
- If the level indicator does not work correctly:*
- ▶ Vary the sensitivity (→ §3.6.3.)
  - ▶ *If that doesn't help:* Change the paddle (size, shape). Then repeat the test and adjust the switching sensitivity again.



*If the bulk material has been changed:*

- ▶ Carry out this test/adaptation again.

## 5 Maintenance

### 5.1 Recommended maintenance work

- ▶ *Clean moving external parts:* Clean off deposits and dirt on paddle and shaft roughly using a scraper and/or a brush. Do not use force. Caution: Do not damage the shaft sealing. Do not allow bristles to get between the shaft and the shaft sealing.
- ▶ *Inspect wearing parts* (highly recommended in case of abrasive bulk material): Inspect the parts that protrude into the bulk material container (shaft/cable, paddle, etc.). Pay special attention to the connecting parts (split-pins, etc.). Replace damaged or questionable parts.
- ▶ *Clean the protective tube* (if the protective tube has open end): Preventatively clean the inside of the protective tube to make sure that the shaft can always freely rotate.
- ▶ *Clean distance tube* (is present – if required for explosion protection → page 9 §3.3.4): Remove dust deposits from the distance tube.

### 5.2 Preventive functional check

If the indicating function is rarely triggered during operation (e.g. for use as a safety switch):

- 1 Inform the connected stations that a test will be carried out.
- 2 Stop the paddle by hand / allow the paddle to rotate freely, and check the triggering of the indicating function.

### 5.3 Internal malfunctions

#### 5.3.1 Electronic self-monitoring

Self-monitoring is constantly active in the electronics.

If the self-monitoring detects a malfunction, then output "OutB" is deactivated (→ page 9 §3.5.2).

### 5.4 Safety information for opening



**WARNING: Health risk / explosion hazard**

- ▶ *Before opening the unit head:* switch-off the power supply and any connected signal voltage at an external point. (Caution: This disables the level indicator.)
- ▶ Only open the housing when you are absolutely sure that there is no possible danger.



- ▶ Do not open when it is under voltage.
- ▶ After switching it off, wait 40 minutes before opening it.

### 5.5 Removing the unit head (note)

The unit head can easily be separated from the process connection without opening the process connection:

- If the unit head is to be removed completely, disconnect the electric cables first.
- Loosen the clamping screw on the underside by approximately 3 mm (3 ... 4 turns).
- Carefully pull the unit head from the process connection along the direction of the shaft. This requires some strength due to the adhesion and friction of the sealing: use controlled force, but no brute force; risk of falling; be prepared for the unit head to become suddenly free.
- Reinstall in the reverse order.
- The clamp screw must be tightened at the medium strength by using a screw lock. (clamp screw: 4 Nm).

## 6 Technical data

### 6.1 Identification

Identification:	 II 1/2 D Ex ta/tb IIIC T100°C Da/Db
Type examination certificate:	DEKRA BVS 17 ATEX E 081 X

### 6.2 Specifications on the rating plate

- Unit type and version code
- Supply voltage
- Explosion protection classification
- Housing protection class
- Minimum surface temperatures:
  - The temperature value  $T_i$  applies to the parts of the unit that protrude into the container.
  - The temperature value  $T_a$  applies to the unit head.



Specifications on the rating plate apply with higher priority.

### 6.3 Electrical data

#### MBA810

Supply voltage:	115 ... 230 V AC, 50/60 Hz
Power consumption:	6 VA (max.) Without connected Appliance

#### MBA820

Supply voltage:	24 V DC $\pm$ 10 %
Power consumption:	6 W (max.)

### 6.4 Ambient conditions

Ambient temperature outside the container (without ATEX):	-30 ... +60 °C
Ambient temperature outside the container (with ATEX)	-20 ... +50 °C
Maximum surface temperature of the product:	see rating plate

## 6.5 Product materials

### Product materials in contact with the bulk material

Shaft, protective tube, process connection, paddle	Steel / stainless steel <sup>1</sup> Aluminium <sup>2</sup> / Silicon
Seals:	Viton / Silicon and PTFE or graphite <sup>2</sup>

<sup>1</sup> Depending on the unit version

<sup>2</sup> Version for 350 °C

### Materials of the unit head

Housing body:	Aluminium
Housing cover:	Aluminium
Housing seal:	Silicon (VMQ)
Screw connections:	PA (gasket: NBR) <i>Option:</i> brass, nickel plated (gaskets: NBR/FPM)
Sealing plugs:	PA
Compensating membrane:	<ul style="list-style-type: none"> <li>● Polyester/PTFE (gasket: silicon)</li> <li>● ATEX version in stainless steel</li> </ul>

6.6 Dimensions

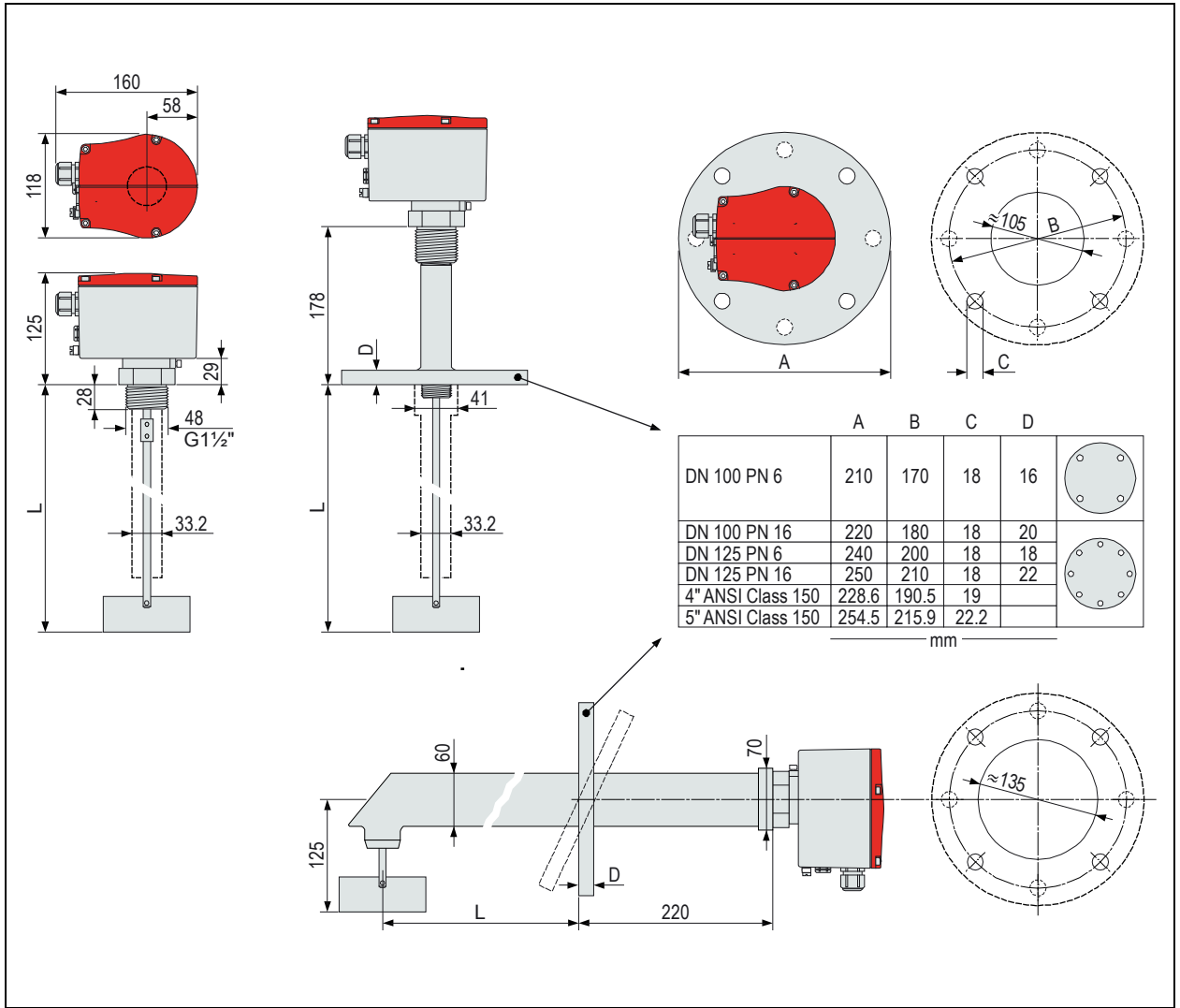

MBA Instruments GmbH  
Friedrich-List-Str. 3-7 · 25451 Quickborn · Deutschland  
Telefon +49 4106/123 88-80 · Fax +49 4106/123 88-89  
[www.mba-instruments.de](http://www.mba-instruments.de) · [info@mba-instruments.de](mailto:info@mba-instruments.de)

